

DESIGN NOTES

LT1580 Fast Response Low Dropout Regulator Achieves 0.4 Dropout at 4 Amps – Design Note 119

Craig Varga

Low dropout regulators have become more common in desktop computer systems as microprocessor manufacturers have moved away from 5V only CPUs. A wide range of supply requirements exists today with new voltages just over the horizon. In many cases, the input-output differential is very small, effectively disqualifying many of the low-dropout regulators on the market today. Several manufacturers have chosen to achieve lower dropout by using PNP-based regulators. The drawbacks of this approach include much larger die size, inferior line rejection and poor transient response.

ENTER THE LT[®]1580

The new LT1580 NPN regulator is designed to make use of the higher supply voltages already present in most systems. The higher voltage source is used to provide power for the control circuitry and supply the drive current to the NPN output transistor. This allows the NPN to be driven into saturation, thereby reducing the dropout voltage by a V_{BE} compared to a conventional design. Applications for the LT1580 include 3.3V to 2.5V conversion with a 5V control supply, 5V to 4.2V conversion with a 12V control supply, or 5V to 3.6V conversion with a 12V control supply. It is easy to obtain dropout voltages as low as 0.4V at 4A, along with excellent static and dynamic specifications.

The LT1580 is capable of 7A maximum with approximately 0.8V input-to-output differential. The current requirement for the control voltage source is approximately 1/100 of the output load current or about 70mA for a 7A load. The LT1580 presents no supply-sequencing issues. If the control voltage comes up first, the regulator will not try to supply the full-load demand from this source. The control voltage must be at least 1V greater than the output to obtain optimum performance. For adjustable regulators, the adjust-pin current is approximately 60 μ A and varies directly with absolute temperature. In fixed regulators, the ground pin current is about 10mA and stays essentially constant as a function of load. Transient response performance is

similar to that of the LT1584 fast-transient-response regulator. Maximum input voltage from the main power source is 7V and the absolute maximum control voltage is 13V. The part is fully protected from overcurrent and over-temperature conditions. Both fixed voltage and adjustable voltage versions are available. The adjustables are packaged in 5-pin TO-220s, whereas the fixed-voltage parts are 7-pin TO-220s.

The LT1580 Brings Many New Features

Why so many pins? The LT1580 includes several innovative features that require additional pins. Both the fixed and adjustable versions have remote-sense pins, permitting very accurate regulation of output voltage at the load, where it counts, rather than at the regulator. As a result, the typical load regulation over a range of 100mA to 7A with a 2.5V output is approximately ± 1 mV. The Sense pin and the V_{CONT} pin, plus the conventional three pins of an LDO regulator, give a pin count of five for the adjustable design. The fixed voltage part adds a GND pin for the bottom of the internal feedback divider, bringing the pin count to six. Pin 7 is a no connect.

Note that the Adjust pin is brought out even on the fixed voltage parts. This allows the user to greatly improve the dynamic response of the regulator by bypassing the feedback divider with a capacitor. In the past, using a fixed regulator meant suffering a loss of performance due to the lack of such a bypass. A capacitor value of 0.1 μ F to approximately 1 μ F will generally provide optimum transient response. The value chosen depends on the amount of output capacitance in the system.

In addition to the enhancements already mentioned, the reference accuracy has been improved by a factor of two, with a guaranteed 0.5% tolerance. Temperature drift is also very well controlled. When combined with ratiometrically accurate internal divider resistors, the part can easily hold 1% output accuracy over temperature, guaranteed, while operating with an input/output differential of well under 1V.

In some cases, a higher supply voltage for the control voltage will not be available. If the Control pin is tied to the main supply, the regulator will still function as a conventional LDO and offer a dropout specification approximately 70mV better than conventional NPN-based LDOs. This is the result of eliminating the voltage drop of the on-die connection to the control circuit that exists in older designs. This connection is now made externally, on the PC board, using much larger conductors than are possible on the die.

Circuit Example

Figure 1 shows a circuit designed to deliver 2.5V from a 3.3V source with 5V available for the control voltage. Figure 2 shows the response to a load step of 200mA to 4.0A. The circuit is configured with a 0.33μF adjust-pin bypass capacitor. The performance without this capacitor is shown in Figure 3. This difference in performance is the reason for providing the Adjust pin on the fixed-voltage devices. A substantial savings in expensive output decoupling capacitance may be realized by adding a small ceramic capacitor at this pin.

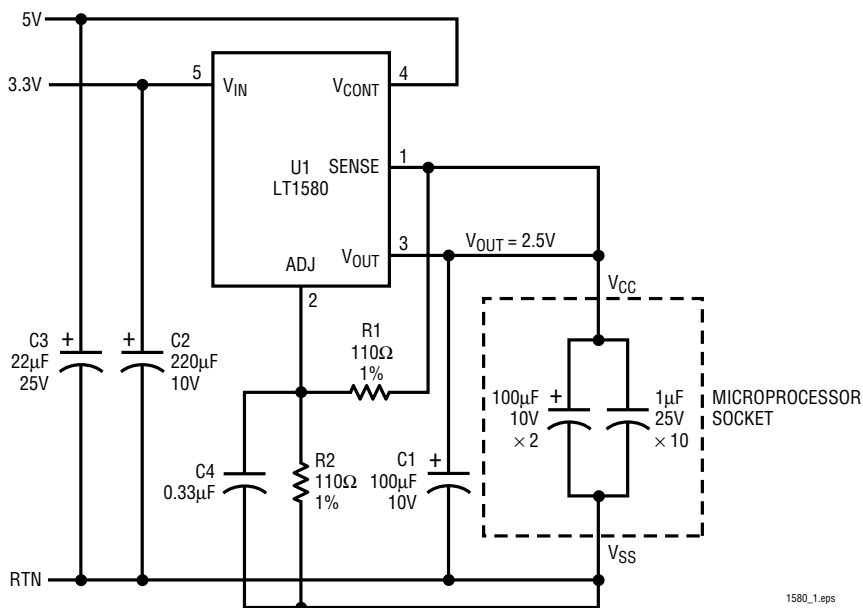

Figure 1. LT1580 Delivers 2.5V from 3.3V at Up to 6A

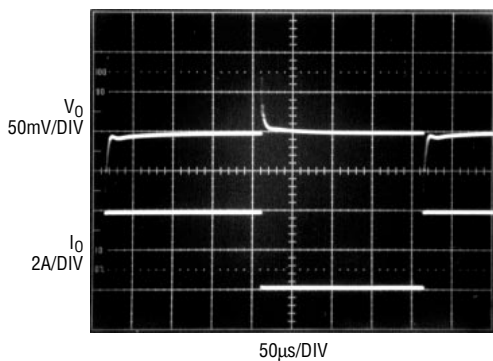

Figure 2. Transient Response of Figure 1's Circuit with Adjust-Pin Bypass Capacitor. Load Step Is from 200mA to 4 Amps

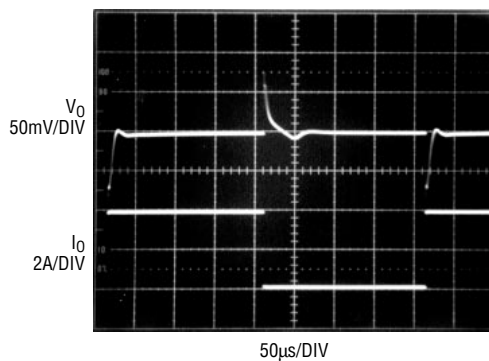

Figure 3. Transient Response Without Adjust-Pin Bypass Capacitor. Otherwise, Conditions Are the Same as in Figure 2

For literature on our Power Products, call **1-800-4-LINEAR**. For applications help, call (408) 432-1900, Ext. 456